



OV6000 Series Observation Lift



Greater Reliability, Greater Comfort

SCH5600 Control System Platform

The brilliant fusion of master control, monitoring, intelligent management and black-box effectively shield off interference produced by the elevator that enhances the overall ride experience. Reliability of the elevator is also boosted with doubled communication capacity and speed. In addition, we are the first in the industry to introduce automated protection to our elevators which reduces breakdown points, frequency of breakdowns and intensity of breakdowns to safeguard the safety of our passengers.

Energy-conserving Traction Machine

Permanent Magnet Traction machine boasts the latest breakthrough best known for its effectiveness in energy conservation and steady torque, raising the transportation efficiency to more than 95%.

Synchronous machine door

The integration of control and drag brake greatly shortened door reaction time and time taken for door opening/closing reducing the frequency of accidents. In our continuous effort to perfect our elevator, we implemented a system which enables the elevator to undergo automatic optimization during critical situations such as lift stop, significant reduction in speed and etc.



Energy-Saving Technology

When the elevator is in stand-by mode, other than the mild-illuminating hall call buttons, all other elevator parts utilize minimum energy. Hence, the total energy used when the elevator is in standby mode is less than 50VA.

Low Radiation

Our control system met the International Electrotechnical Commission IEC255 requirements comprising of EMC inspection which is in line with EN12015 and EN12016 standards. With higher resistance for interference, it improves the stability of the elevator during transportation and the reduction in electromagnetic radiation minimizes the negative effects it has on human body significantly.

Noise Reduction

Equipped with 5 noise-reducing techniques and a quiet traction machine, noise level is effectively reduced to 43dB.

Variable Voltage Variable Frequency (VVVF) Lift Drive

Variable Voltage Variable Frequency (VVVF) Lift Drive employs frequency inverter technology which regulates input voltage and frequency throughout the journey, drawing much less current during acceleration and deceleration.

VVVF drive offers low starting current (approximately 1.8x of the rated current), high power factor (i.e. better efficiency in power supply) with good ride quality and floor leveling. It can reduce motor starting currents by as much as 50 to 80% compared with conventional motor drives. Further, wear and tear of the equipment can also be less during start/stop of the motor by using VVVF motor drive. BCA Green Mark compliance.

According to data analysis, XJ Schindler elevators waste reduces 52% more energy in standby mode.



Leading energy conservation technology reduces 52% power consumption by elevators in standby mode

XJ Schindler unique patentship
Satisfies VDI 4707 A grade standard

XJ Schindler
standby mode
energy usage
47W

≤



XJ Schindler Series Elevators can transit smoothly between hibernate mode when left unused for a prolonged period of time and normal mode when in use. This greatly reduces the power consumption of elevators to a mere 47W.

Reference:

According to records: The effective operation of an elevator operating on a 24-hour basis is only 3-6 hours. When the elevator is on standby mode, the power wastage is approximately 300W. Cumulatively, the overall power wasted per year is approximately 2100kWh. This implies that supposedly, \$1200 can be saved from the power wastage when elevator is in standby mode. The total amount of energy wasted by the world is almost equal to the total energy produced by QinShan Nuclear Station for 10 years.

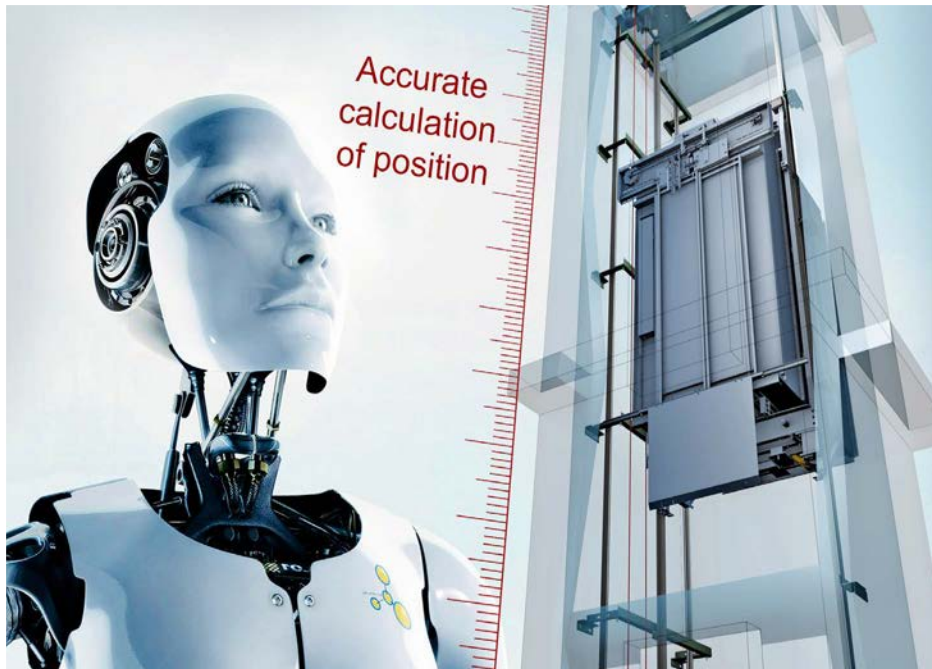

Lift Slide Protection Patent

Eliminates Lift Slide Incidents

When the lift doors are opened, lift slide incidents can occur due to a spectrum of reasons. Before lift slide incidents can even actualise, our door protection system will be able to detect any abnormal movements by the elevator. When the elevator slide by 5cm, the protection system will be activated and the elevator will brake and stop within 20cm from the landing level. This prevents major lift slide incidents from occurring.

5cm

Start of protection

20cm

Safety Brake

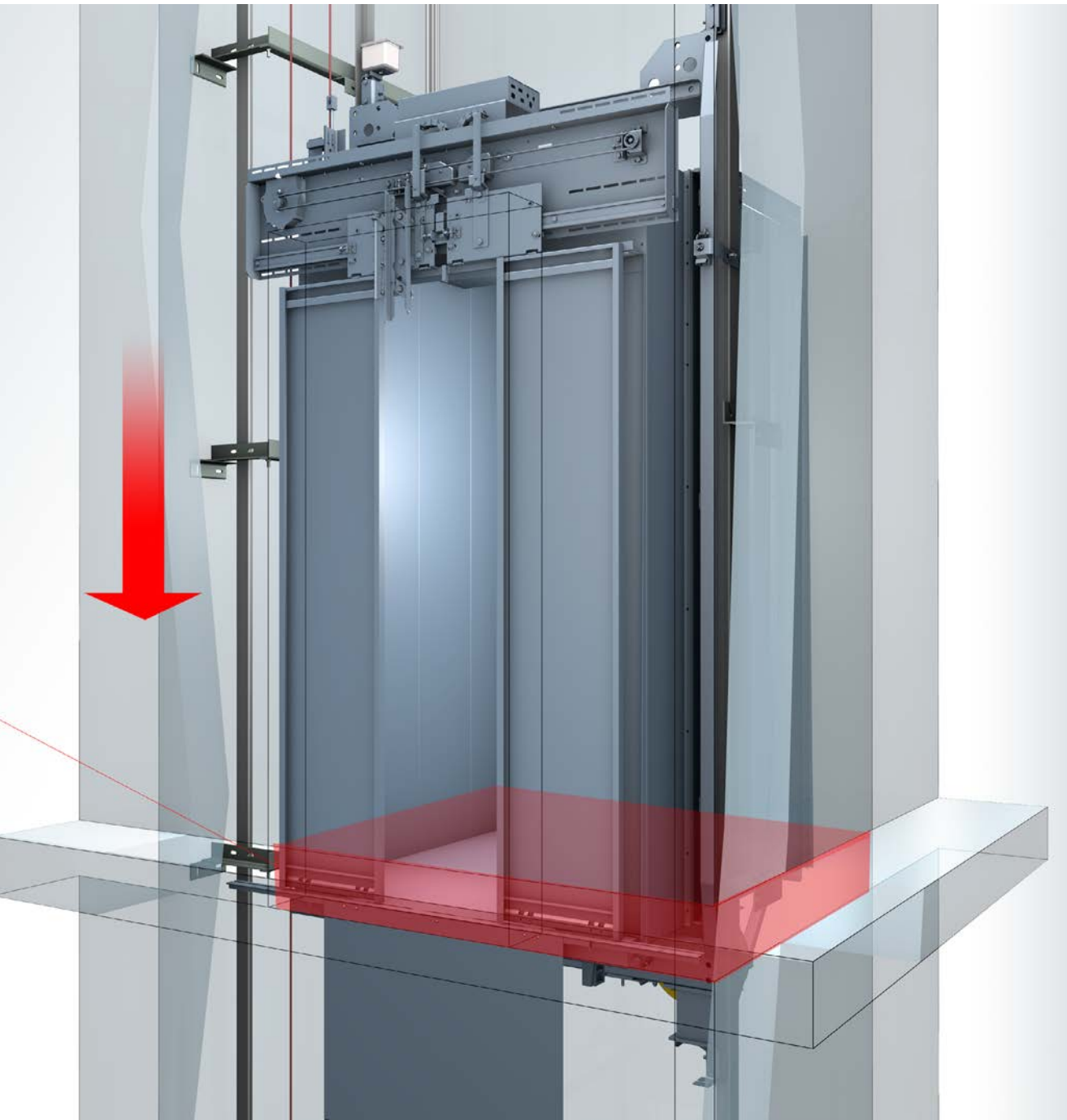

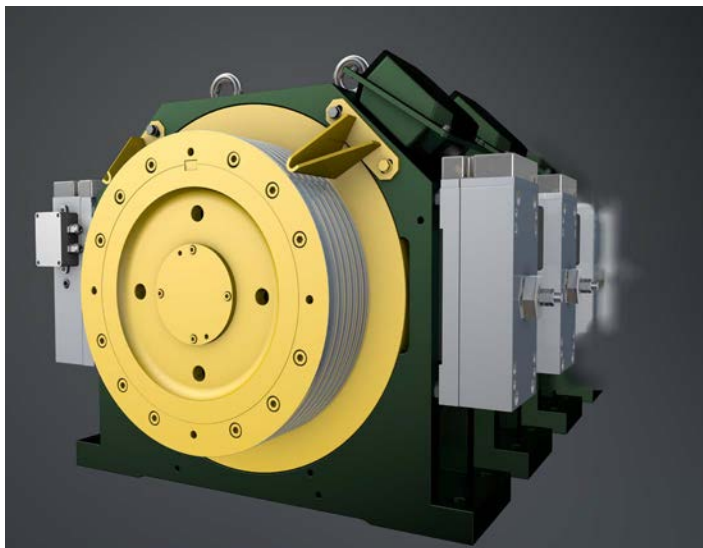

XJ Schindler High-Power Sixth Generation Traction machine

- High-performance braking system
- Efficient and excellent torque
- Stable and low-noise
- 100% Full dynamic testing at the factory
- Awarded with 2 patent technologies



Stable and Reliable **XJ Schindler** Control System

- In our military grade dual 32-bit CPU chip, each individual chip has independent operator to manage the data and information.
- With the CPU chips operating independently from one another, it completely isolates the input and output information, hence effectively reduces interruption.
- 4 way Canbus main control, up to 9 external midrange, suitable for control of complex industries.
- Recognition from International Safety committee
- Modular industrial design with flexible configuration to suit different environments.
- Excellent heat dissipation design
- Qualified IEC255, EN12015, EN12016, IEC61000, CISPR11 Standards

Accurate and reliable synchronous direct drive door system

- Permanent Magnet Traction machine is advance and reliable.
- Simultaneous closure of landing door and car door and full control of door opening/closing
- High efficiency and speed: Door opening/closing duration 2.04s
- Low noise: Door noise of 38dB
- Recognised by World Elevator Quality Supervision and Inspection WTNET13-004



180° Semi-circle Wide View Observation Lift. 1:1 ratio of actual product. Top view.

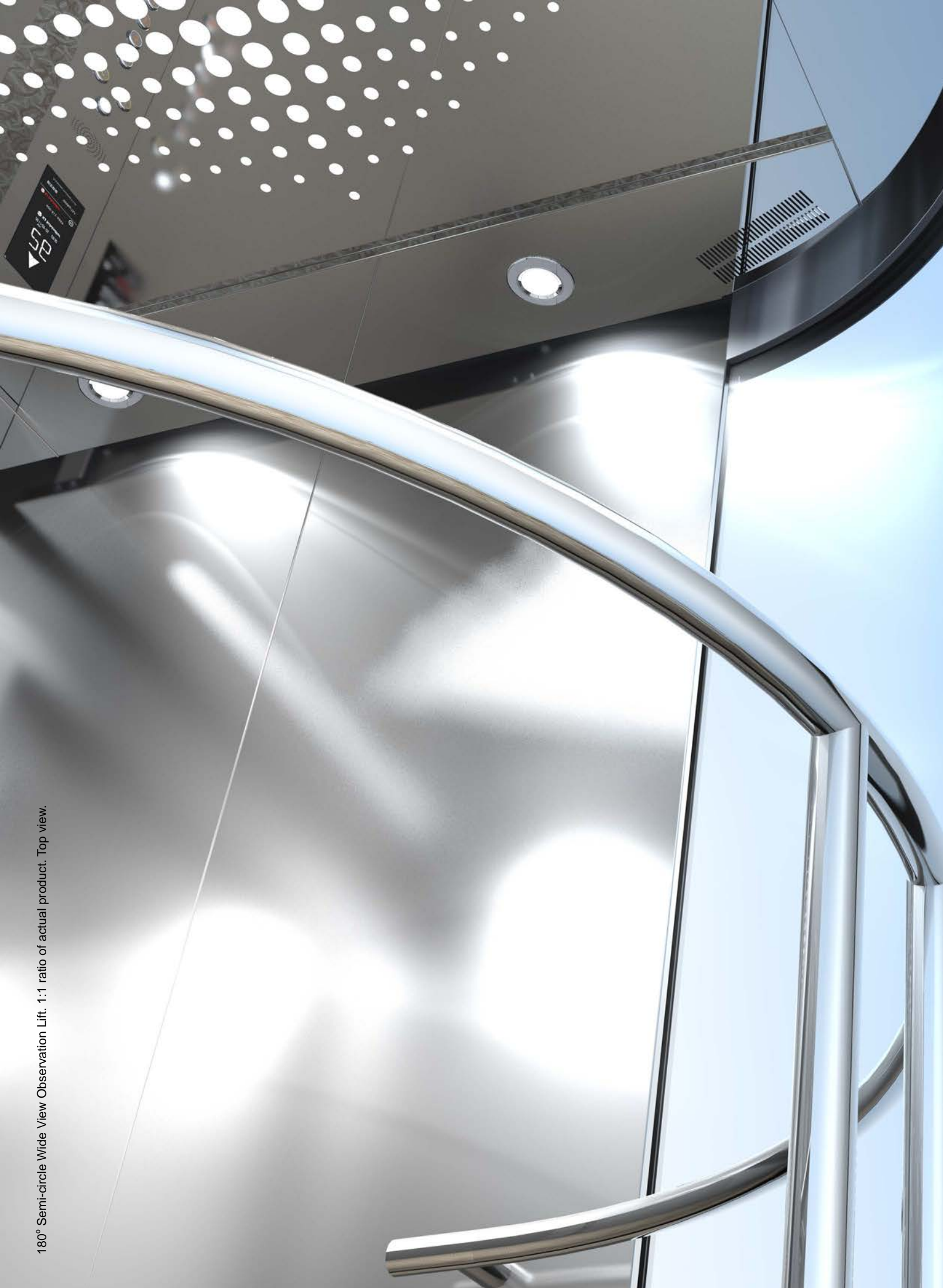

180° Semi Circle Wide View Observation Lift

Our versatile 180° observation elevator adds a touch of elegance to almost any building structures.



OV 01

Upper/lower casing S/S Mirror with Acrylic Lighting

Observation wall Laminated Glass

Ceiling X12C S/S Mirror

Car walls S/S Hairline

Flooring Heavy duty vinyl flooring

Handrail S/S Mirror

Swing COP

Indicator LCD

Button Braille buttons with mild illumination

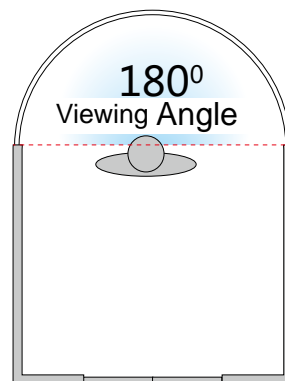

Actual product may vary from picture

270° Three-sided View Observation Lift, 1:1 ratio of actual product. Top view.

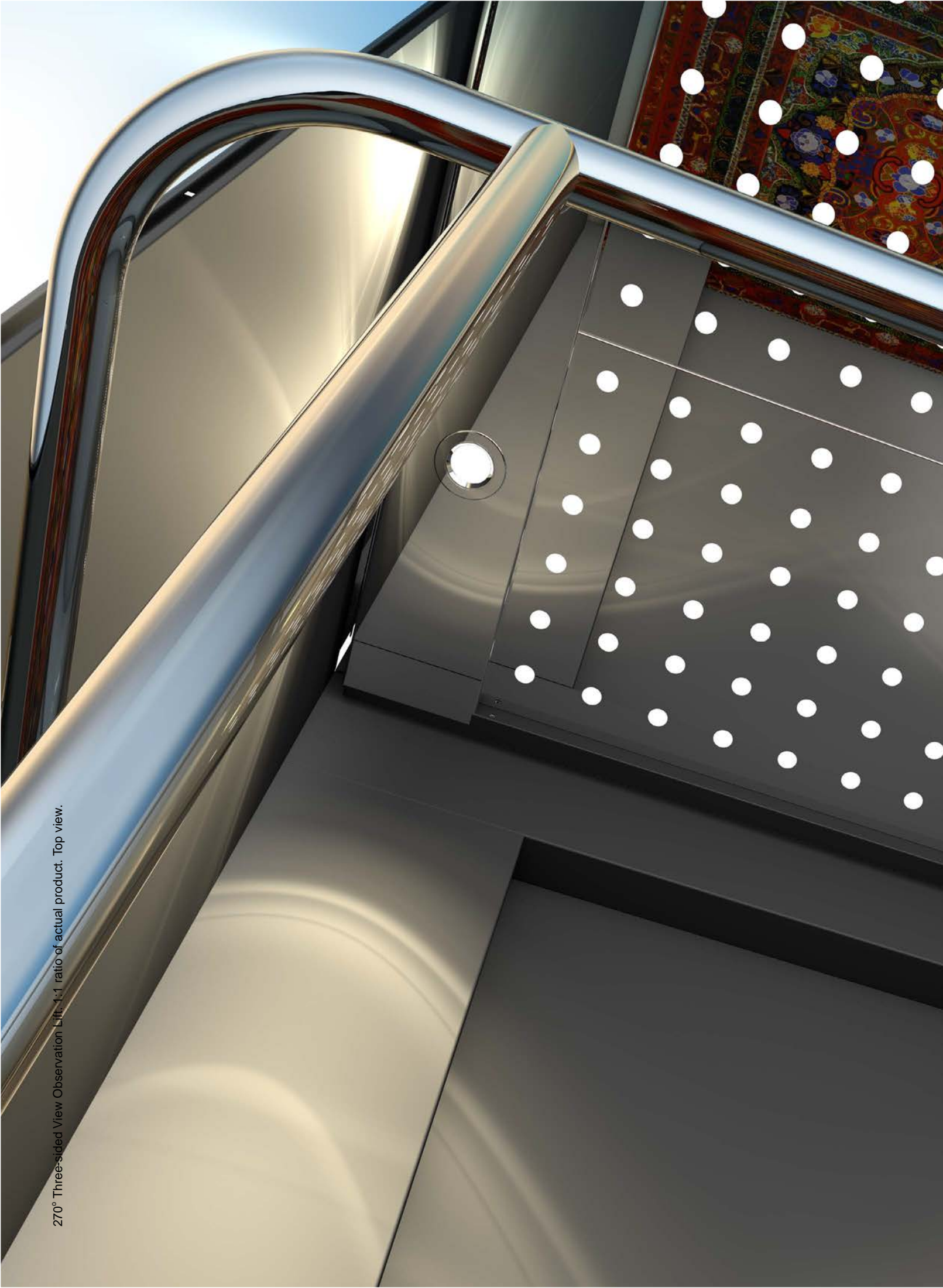

270° Three-sided View Observation Lift

This model emphasizes on the boundless ambience bringing about a refreshing feeling to the passengers.



OV 02

Upper/lower casing	S/S Hairline with Acrylic Lighting
Observation wall	Laminated Glass
Ceiling	X05C S/S Mirror
Car walls	S/S Hairline
Flooring	Heavy duty vinyl flooring
Handrail	S/S Mirror
Swing COP	
Indicator	LCD
Button	Braille buttons with mild illumination

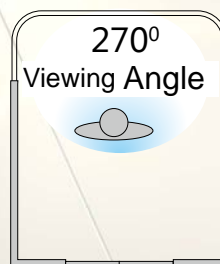

Actual product may vary from picture

180° Semi Circle Observation Lift. 1:1 ratio of actual product. Top view.





180° Semi Circle Observation Lift

Embellished with bright illuminations on the external wall, the 180° Semi Circle Observation Elevator presents a luxurious impression.



OV 03

Upper/lower casing	S/S Hairline with Acrylic Lighting
Observation wall	Laminated Glass
Ceiling	S/S Mirror
Car walls	S/S Hairline
Flooring	Heavy duty vinyl flooring
Handrail	S/S Mirror

Swing COP

Indicator LCD

Button Braille buttons with mild illumination

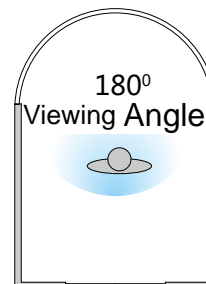

Actual product may vary from picture

360° Stereoscopic Full View Observation Lift. 1:1 ratio of actual product. Top view.

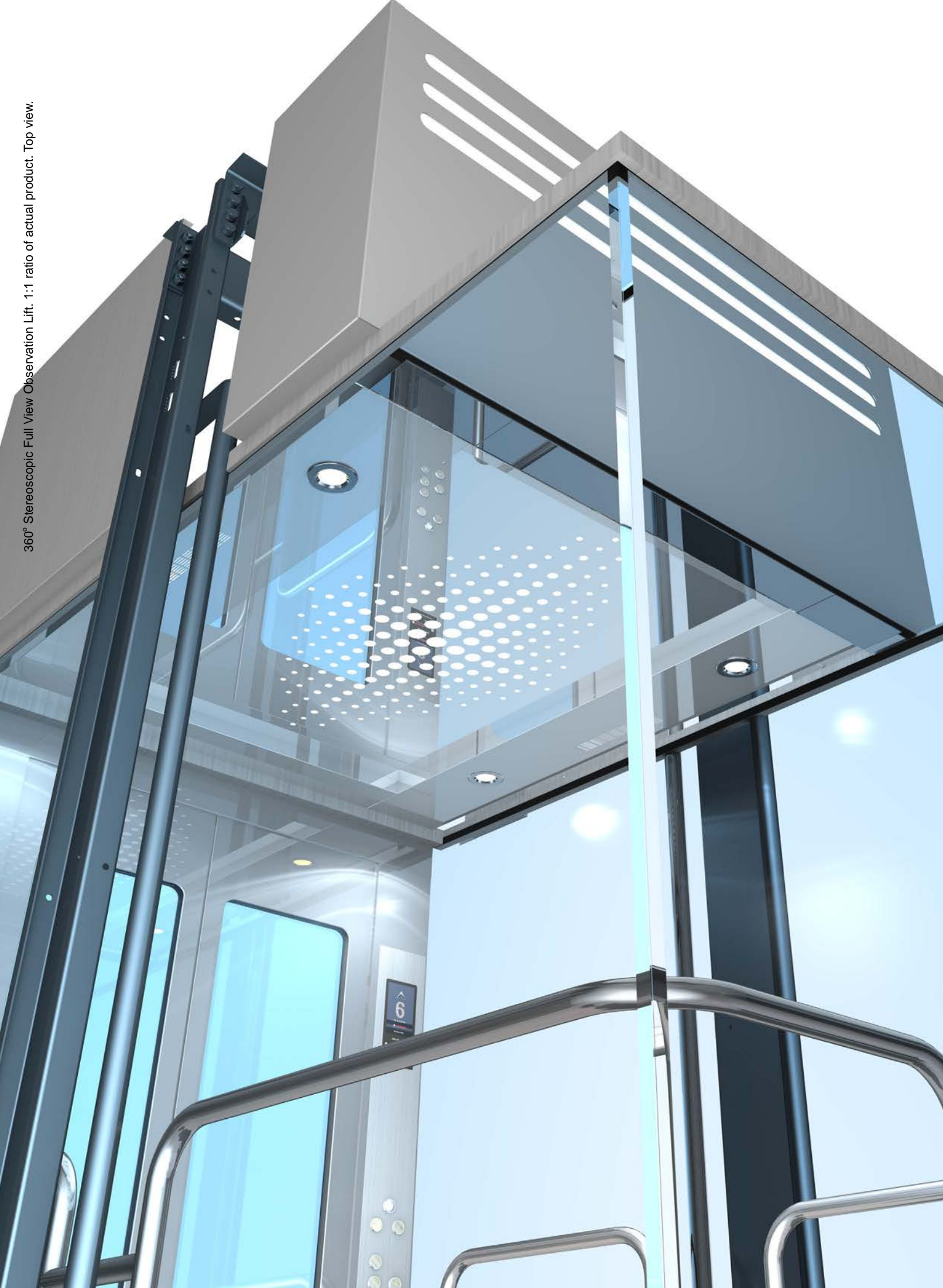

360° Stereoscopic Full View Observation Lift

With a full steel shaft, this model of observation elevator is surrounded by 4 full-length glass walls offering greater viewing angles to all passengers.

OV 04

Upper/lower casing S/S Mirror with Acrylic Lighting

Observation wall Laminated Glass

Ceiling S/S Mirror

Car walls S/S Hairline

Flooring Heavy duty vinyl flooring

Handrail S/S Mirror

COP

Indicator TFT True Colour Display (Optional)

Button Braille buttons with mild illumination

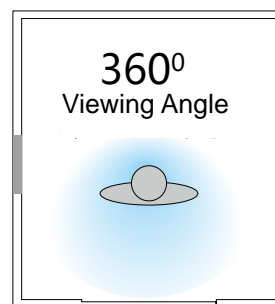

Note: Request for common colour for hoistway steel and car cage

Actual product may vary from picture

90° Single View Observation Lift. 1:1 ratio of actual product. Top view. Top view.



90° Single View Observation Lift



OV 05

Upper/lower casing	S/S Hairline with Acrylic Lighting
Observation wall	Laminated Glass
Ceiling	X05C S/S Hairline
Car walls	S/S Hairline
Flooring	Heavy duty vinyl flooring
Handrail	S/S Mirror
Swing COP	
Indicator	LCD
Button	Braille buttons with mild illumination

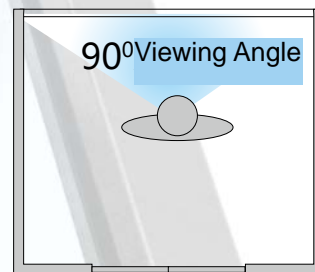

Car Operating Panel Display



LCD Display
(Standard)
Clear text and large
viewing angle



TFT True Colour
Display (Optional)
Vibrant colours with
realistic effect



TFT Display System
(Optional)
Vivid display and able
to project multimedia of
different formats.

Hall Call



HT-19FD (Standard)
Dot Matrix Display
S/S Mirror Plate



HT-19FT2 (Optional)
LCD Display
S/S Mirror Plate

Note: Base level as standard

Hall Lantern (Optional)



DZD-JF
Square crystal lantern
S/S mirror plate



DZD-JS
Diamond crystal lantern
S/S mirror plate

OV6000 Series Observation Lift Standard Functions

No.	Function	Description
1	Group control	Elevator will decide on which level to serve when it receives cues from both inside and outside of the elevator. The selection will be based on the most efficient allocation of service to shorten passengers' waiting time.
2	Attendant operation	After activation, the stop floor is selected by the elevator operator. All hall calls can still be responded when the elevator is in attendant operation mode.
3	Auto-door opening when power on	If the lift is at door area, car door will open automatically when elevator is switched on.
4	Auto-closing delay	After the car doors are fully opened, there will be a 2-5 seconds delay before the doors close.
5	Door holding time adjustment	The delay between door opening and door closing can be customized to cater to different needs.
6	Door close protection	If the car door fails to close after 6 attempts, the elevator will shut down automatically and the emergency alarm will sound.
7	Door lock protection	Elevator can continue its operation only when the doors are fully closed and locked. The elevator will go into protection mode if the elevator jars or the door locks break off.
8	Door system protection	Our car doors have 10 protections to prevent accidents from happening when the car doors open.
9	Auto-leveling	Car door will open automatically when the hall call button is pressed if the lift is at door area.
10	Advance closing	Under normal circumstances, doors will close in advance when door close button is depressed.
11	Auto-opening	When the elevator reaches its destination, the car doors will open automatically.
12	Maintenance operation	When the lift is in maintenance mode, it will move at maintenance speed for the convenience of the repairmen.
13	Low-speed self rescue	Under non-maintenance mode, the lift will move towards the nearest landing floor at a much slower speed if the lift did not stop at door area.
14	Hoisting self-learning	The hoistway must have captured a series of data (eg. level height, protection switch position, deceleration switch position, etc) and retain the information permanently before the elevator can travel at higher speed.
15	Sunken button	If the hall call button is being depressed for more than 20 seconds, the system will consider the button to have sunken in and will not respond to the cue. The hall lantern at corresponding lift level will blink.
16	Fault recovery due to power failure	Once the power supply recovers, elevator will move to the nearest landing floor and restore its normal operation.
17	WDT protection	When the system detects malfunctions in CPU or program, the WDT protection will deactivate functions of car operating panel for the CPU to recover.
18	Screen protection	We have installed screen protection system on our door such that when the screen is touched, the doors will stop closing and open instead.
19	Speed protection	If the control device detects that the speed of the elevator is greater than 115% of its speed limit for more than 500ms, the elevator will decelerate till an eventual stop. If the elevator did not recover to its normal speed after 2 attempts, the car operating panel will be deactivated and emergency alarm will sound.
20	Overload protection	This system will activate an audio/ visual signal and prevent the elevator from moving when it is overloaded.
21	Retrogradation protection	If the control device detects that the elevator is travelling in reverse direction for more than 3 seconds, the elevator will stop and emergency alarm will sound.
22	Lift slide protection	If the actual speed of elevator does not correspond with the theoretical speed measured by AB encoder, this implies that the elevator may be sliding. Elevator will stop and enter 5 levels of fault conditions.

No.	Function	Description
23	Overshoot protection	The elevator speed will be reduced by force if the elevator fails to reduce to its preset speed as it is approaching the terminal level.
24	Contact point inspection	If there is any abnormality in motor circuit contactor, the elevator will enter protection mode and the system will be able to determine the type of abnormality accurately.
25	Safety loop protection	In events when any part of the elevator breaks down, the safety loop will disconnect and the elevator will stop operating.
26	Overspeed protection	Elevator will stop and emergency alarm will sound when the travelling time for 1 trip exceeds the total travelling time for the whole building.
27	Limit protection	When the system detects the deactivation of limit switch, the elevator will stop and travel in reverse direction until the landing door is opened.
28	Final limit protection	When the system detects the deactivation of final limit switch, the elevator will enter protection mode.
29	Brake inspection	Real time examination of brake opening status. If the brake did not open according to command, the system will stop the start-up of elevator.
30	Inverter fault protection	When the system receives error signal from inverter, the elevator will undergo emergency stop to prevent movement of elevator. The elevator will recover automatically when the error is removed.
31	Encoder signal loss protection	When the lift is in operation and the system detects that the encoder signal is lost or pulse count is lower than usual, the elevator will enter protection mode.
32	Fireman operation	When the fireman switch is being activated, the elevator will cancel all hall calls and return to fire base level. The elevator will then enter firemen operating status.
33	Lift slide alarm	When the elevator stops, the system will generate feedback pulse for 3 seconds. If the feedback pulse fails to recover the elevator, the alarm for lift slide will sound.
34	Auto-docking during breakdown	If the elevator stops at non-gate area when the elevator is travelling at high speed, the elevator will travel slowly towards the nearest landing floor if the safety circuit is under normal condition.
35	Overload bypass	When car is fully loaded, it will only respond to car calls and bypass all hall calls.
36	Mischievous call cancel	Based on counter-weight logic, the system will prevent movement of empty elevator by cancelling cues from car operating panel. This is to prevent wrong signals from being given out by the car operating panel or pranks.
37	Floor lock operation	Specific floors can be locked out as non-stop floor through system configuration.
38	Lift lock service	When the lift lock service is being activated, the elevator will complete all calls entered prior to the activation and return to the designated level. At the same time, the elevator will enter power saving mode, cutting off car lights and light up elevator stoppage indicator in the hall.
39	Door open at next landing floor	If landing door fails to open at the designated floor after 8 seconds, the elevator will send the passengers to the nearest available floor to let the passengers out.
40	Automatic returning function	Elevator will be docked at the designated level and be in stand-by mode if it did not receive any call for more than the designated period of time.
41	Communication system	Communication with motor room, car top, car pit and control room can be done using the car operating panel intercom. (Wiring of cables from motor room to the control center will have to be done by customers)
42	Arrival gong	An electronic chime located at the car top sounds just before the arrival of the elevator
43	Emergency lighting	Emergency lighting will be activated automatically during power failure.
44	Absolute position control	To ensure reliability of our elevators, we employed car locator technology to actualize non-falling elevator control.
45	Standby mode	When the elevator is in stand-by mode, other than the mild-illuminating hall call buttons, the other elevator parts utilize minimum energy. Hence, the total energy used when the elevator is in stand-by mode is less than 50VA. When the elevator detects passengers, it will return to its original energy usage

OV6000 Series Observation Lift Optional Functions

No.	Function	Description
1	Advance opening	When the lift reduces speed as it approaches the door area, doors will start opening before the lift stops .
2	Duplex control	Fully automatic operation used for a two elevator system. Calls are responded to by whichever car that can serve the call faster. When there is no call, one of the cars will standby at the starting floor while the other car stops at the pre-designated floor.
3	Group control	The maximum number of elevators that can be controlled in group control system is 8 elevators. In group control system, the elevators can arrange themselves such that they will be able to provide the best response which shortens the waiting time for lift and is most energy saving. This also reduces lift shut down episodes.
4	Safety Edge	Our safety touch screens provide double protection for our passengers. When screen is touched, the lift door will stop closing and opens up automatically.
5	Cushioning	During lift installation or maintenance, the sides of the elevator will be cushioned to prevent damages to the car walls. The protective layers can be removed during normal usage of the lift.
6	Automatic rescue device for power failure	When main power failure occurs, the elevators will switch to use the standby power supply automatically and send the lift to the nearest landing floor at a much slower speed to let the passengers out.
7	Car door lock	If the elevator stops at a non-landing floor, the system will lock the car door to prevent passengers from climbing out of the cabin.
8	Video monitoring port (in-car monitoring/ area monitoring)	Reserve a monitoring port for installation of video surveillance. (Customers are responsible for the surveillance equipment and cabling for motor room and surveillance centre)
9	Energy renewal	The potential energy lost during the descent of the elevator can be converted into power supply by passing the DC power supply through a rectifier. This conversion will equalize the voltage between the 2 sources and the resulting energy will return to the main power supply which can be used to power energy-operated equipment.
10	Voice synchroniser	Audio indication of arrival of lift and the corresponding floor level to the passengers inside and outside of the elevator.
11	Hall lantern	Hall lanterns can be provided instead of hall indicators
12	Seismic control	Elevator will be sent to the nearest landing floor when seismic signal is received.
13	Elevator air-con	Air-conditioner can be included in the elevator.
14	Automatic on/off	Automatic on/off elevator to conserve energy when not in use.
15	Monitoring Interface	Our elevator monitoring interface can provide the status of the elevator.
16	Card reader service	Passengers will have to swipe their ID card on the card reader on the car operating panel before they can operate the elevator.
17	LCD display	The LCD true colour display provides a clear presentation of the level details and lift status.
18	Emergency rescue	When the safety loop is faulty, the elevator will take emergency measures to let the passengers out as soon as possible and restore the elevator back to normal use.

Contact **XJ Schindler** to know more!